



SERVICE BULLETIN

QUALITY INFORMATION ANALYSIS
OVERSEAS SERVICE DEPT. MITSUBISHI MOTORS CORPORATION

SERVICE BULLETIN		NO.: MSB-97E11-502	
		DATE: 1997-02-28	<MODEL> ECLIPSE(D30) 96-10 CARISMA 96-10
SUBJECT: CHANGE IN LASH ADJUSTER CHECKING PROCEDURE			
GROUP: ENGINE		DRAFTNO.: 96-AL-504	
CORRECTION	OVERSEAS SERVICE DEPT	 R. USAMI - MANAGER QUALITY INFORMATION ANALYSIS	

1. Description:

The lash adjuster checking procedure has been changed as follows:

2. Applicable Manuals:

Manual	Pub. No.	Page	Engine Model
'96 ECLIPSE Workshop Manual - Chassis	PWUE95E1(English)	11A-12~11A-14	4G63-DOHC
	PWUF95E1(French)		
	PWUG95E1(German)		
	PWUD95E1(Dutch)		
'96 CARISMA Workshop Manual - Chassis	PWDE9502(English)	11A-15~11A-17	4G93-DOHC
	PWDS9503(Spanish)		
	PWDF9504(French)		
	PWDG9505(German)		
	PWDD9506(Dutch)		
	PWDW9507(Swedish)		

3. Details:

ENGINE – On-vehicle Service

LASH ADJUSTER CHECK

If an abnormal noise (chattering noise) suspected to be caused by malfunction of the lash adjuster is produced immediately after starting the engine and does not disappear, perform the following check.

NOTE

1. An abnormal noise due to malfunction of the lash adjuster is produced immediately after starting the engine and changes with the engine speed, irrespective of the engine load.
If, therefore, the abnormal noise is not produced immediately after starting the engine or does not change with the engine speed, or it changes with the engine load, malfunction of the lash adjuster is not the cause for the abnormal noise.
 2. When the lash adjuster is malfunctioning, the abnormal noise is rarely eliminated by continuing the warming-up of the engine at idle speed.
However, the abnormal noise may disappear only when seizure is caused by oil sludge in the engine whose oil is not maintained properly.
- (1) Start the engine.
 - (2) Check if abnormal noise produced immediately after starting the engine changes with the change in the engine speed. If the abnormal noise is not produced immediately after starting the engine or it does not change with the engine speed, malfunction of the lash adjuster is not the cause for the noise. Therefore, investigate other causes. For your information, the abnormal noise is probably caused by some other parts than the engine proper if it does not change with the engine speed. (In this case, the lash adjuster is in good condition.)
 - (3) With the engine idling, change the engine load (shift from N to D range, for example) to make sure that there is no change in the level of abnormal noise.
If there is a change in the level of abnormal noise, a tapping noise due to worn crankshaft bearing or connecting rod bearing is suspected. (In this case, the lash adjuster is in good condition.)
 - (4) After completion of warming-up, run the engine at idle to check for abnormal noise.
If the noise is reduced or disappears, make the following check as it is suspected that the noise is due to seizure of the lash adjuster. If there is no change in the level of the abnormal noise, proceed to step (5).

ENGINE – On-vehicle Service

- 1) Cool the engine sufficiently.
- 2) Give two turns to the crankshaft.
- 3) Perform simple check of the lash adjuster. (See page 5 of this Service Bulletin.)
 - Replace the lash adjuster which allows the rocker arm to be pushed down easily.
 - If the lash adjuster is found normal as a result of simple lash adjuster check (the rocker arm is not pushed down easily), investigate other causes for the abnormal noise.

NOTE

The lash adjuster can be judged correctly by the leak down test whether it is good or bad. (Refer to ENGINE WORKSHOP MANUAL)

Caution

Before installation of a new lash adjuster, be sure to bleed air from the adjuster. (Refer to ENGINE WORKSHOP MANUAL)

- (5) Run the engine to bleed the lash adjuster system. (See page 7 of this Service Bulletin.)
- (6) If the abnormal noise does not disappear after air bleeding operation, perform the following check.
 - 1) Perform simple lash adjuster check. (See page 5 of this Service Bulletin.)
 - If only one of the lash adjusters is found abnormal in the simple lash adjuster check (the rocker arm is pushed down easily), replace the lash adjuster.
 - If two or more lash adjusters are found abnormal (the rocker arm is pushed down easily), clogged oil passage in the cylinder head is suspected. Check for clogged oil passage and repair the passage if it is clogged. If the passage is not clogged, replace the lash adjusters.
 - If all the lash adjusters are found normal (the rocker arms are hard to push down) as a result of simple lash adjuster check, investigate other causes for the abnormal noise.

NOTE

The lash adjuster can be judged correctly by the leak down test whether it is good or bad. (Refer to ENGINE WORKSHOP MANUAL)

ENGINE – On-vehicle Service

Caution

Before installation of a new lash adjuster, be sure to bleed air from the adjuster. (Refer to ENGINE WORKSHOP MANUAL)

- (7) Start the engine and make sure that the abnormal noise has disappeared. Perform air bleeding operation if required. (See page 8 of this Service Bulletin.)
- (8) On DOHC engine (except 4G15-DOHC), the lash adjuster can easily be replaced by the following procedure.

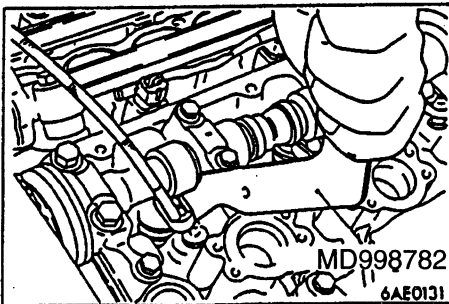

Caution

Before removing the lash adjuster, turn the crankshaft to lower the piston of the cylinder concerned. Otherwise, the valve will come into contact with the piston when the valve is lowered.

In addition, the lash adjuster cannot be removed at the rocker arm lifted by the cam.

In this case, turn the crankshaft so that the rocker arm may not be lifted by the cam.

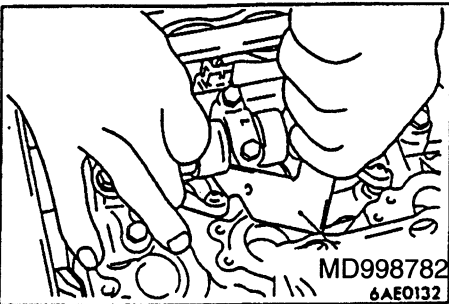

- 1) Use the special tool to push down the valve and remove the roller rocker arm.
- 2) Pull out the lash adjuster from the cylinder head.
- 3) Install on the cylinder head the new lash adjuster from which air has been bled.
- 4) Use the special tool to push down the valve and install the roller rocker arm.

NOTE

To install the roller rocker arm, place the pivot end of the rocker arm on the lash adjuster first. Then, push down the valve and place the slipper end of the rocker arm on the valve stem end.

ENGINE – On-vehicle Service

<Simple Lash Adjuster Check>

- (1) Stop the engine.
- (2) Remove the rocker cover.
- (3) Set the piston in No.1 cylinder at top dead center of the compression stroke.
- (4) Check the rocker arms indicated by a white arrow in the figure next page by the following procedure.

<Except checking of Y-shaped rocker arm>

- 1) Check if the rocker arm can be pushed down when pushing it at the portion right above the lash adjuster.
 - If the rocker arm can be pushed down easily, record the corresponding lash adjuster as a defective.
 - If the rocker arm cannot be pushed down (it feels very stiff), the lash adjuster is in good condition. Therefore, investigate other causes of the abnormal noise.

<Checking of Y-shaped rocker arm>

NOTE

The Y-shaped rocker arm on exhaust valve side cannot be pushed down if either of the lash adjusters is in good condition.

Therefore, use a feeler gauge to make a check by the following procedure.

- 1) Check if a 0.1 – 0.2 mm leaf of the feeler gauge can be inserted between the valve and the lash adjuster.
 - 2) Record the corresponding lash adjuster as a defective if the leaf of the feeler gauge can be inserted easily.
 - 3) If the feeler gauge leaf cannot be inserted easily, the lash adjuster is in good condition. Therefore, investigate other cause of the abnormal noise.
- (5) Slowly turn the crankshaft 360° clockwise.
 - (6) Follow the same procedure as step (4) to check the rocker arms indicated by a black arrow in the figure next page.

ENGINE – On-vehicle Service

In-line 4-cylinder engine (W-E) – Except Carisma

<SOHC-8valve>

← Timing belt side

Exhaust valve side

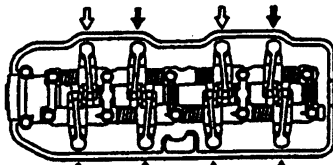

Intake valve side

<SOHC-16valve>

← Timing belt side

Exhaust valve side

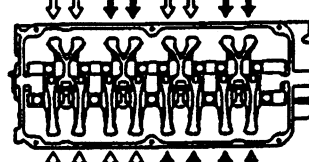

Intake valve side

<DOHC>

← Timing belt side

Exhaust valve side

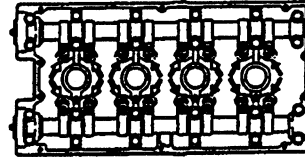

Intake valve side

In-line 4-cylinder engine (E-W) – Carisma

<SOHC-16valve>

← Timing belt side

Intake valve side

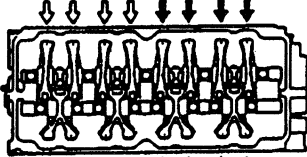

Exhaust valve side

<DOHC>

← Timing belt side

Intake valve side

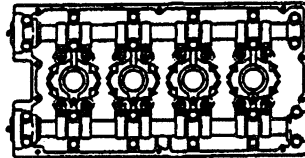

Exhaust valve side

6EN999X

ENGINE – On-vehicle Service

<Bleeding lash adjuster system>

NOTE

1. Parking the vehicle on a grade for a long time may decrease oil in the lash adjuster, causing air to enter the high pressure chamber when starting the engine.
2. After parking for many hours, oil may run out from the oil passage and it takes time before oil is supplied to the lash adjuster, causing air to enter the high pressure chamber.
3. In the above cases, abnormal noise can be eliminated by bleeding the lash adjuster system.

- (1) Check engine oil and add or change oil if required.

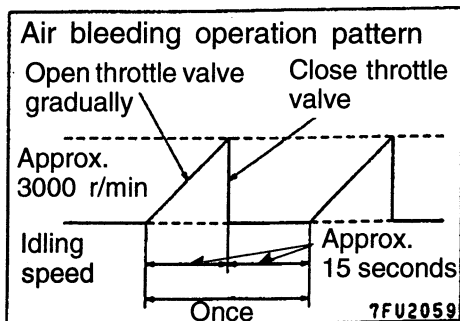
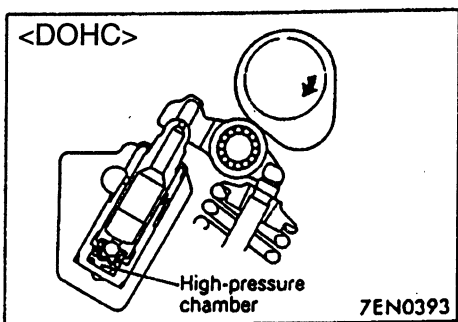
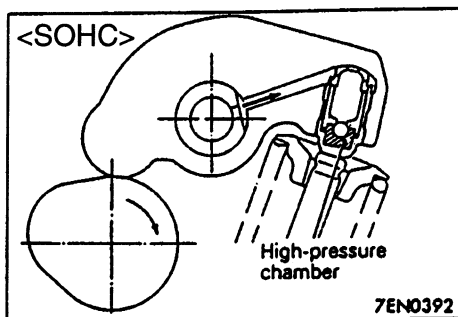
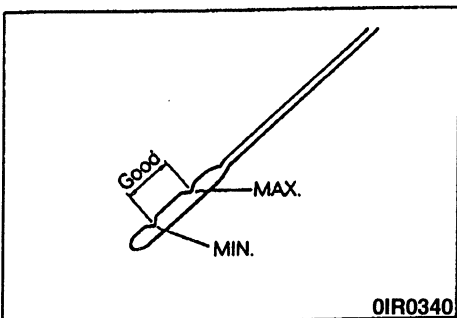

NOTE

1. If the engine oil level is low, air is sucked from the oil screen, causing air to enter the oil passage.
2. If the engine oil level is higher than specification, oil may be stirred by the crankshaft, causing oil to be mixed with a large quantity of air.
3. If oil is deteriorated, air is not easily separated from oil, increasing the quantity of air contained in oil.
4. If air mixed with oil enters the high pressure chamber inside the lash adjuster from the above causes, air in the high pressure chamber is compressed excessively while the valve is opened, resulting in production of abnormal noise at closing of the valve.

This is the same phenomenon as that observed when the valve clearance has become excessive. The lash adjuster can resume normal function when air that has entered the lash adjuster is removed.

- (2) Idle the engine for one to three minutes to warm it up.
- (3) Repeat the operation pattern, shown in left figure, at no load to check for abnormal noise. (Normally the abnormal noise is eliminated after repetition of the operation 10 to 30 times. If, however, no change is observed in the level of abnormal noise after repeating the operation more than 30 times, it is suspected that the abnormal noise is due to some other factors.)
- (4) After elimination of abnormal noise, repeat the operation shown in left figure five more times.
- (5) Run the engine at idle for one to three minutes so as to make sure that the abnormal noise has been eliminated.